

# **Repair Instructions**

## **RE 520/521 Series**



# Contents

<b>Chapter 1: RE 520/521 Series Diagram.....</b>	<b>5</b>
Exploded View.....	6
<b>Chapter 2: RE 520/521 Series Service Instructions.....</b>	<b>9</b>
Motor Section Disassembly.....	10
Housing/Shaft with Seal Carrier Disassembly & Assembly.....	10
Housing/Shaft without Seal Carrier Disassembly & Assembly.....	11
Motor Section Assembly.....	12
<b>Chapter 3: RE 520/521 Series Parts Listing.....</b>	<b>15</b>
Replacement Kits.....	16



---

# Chapter

# 1

---

## RE 520/521 Series Diagram

---

### Topics:

- [RE 520/521 Exploded View](#)

## RE 520/521 Exploded View

### Exploded View

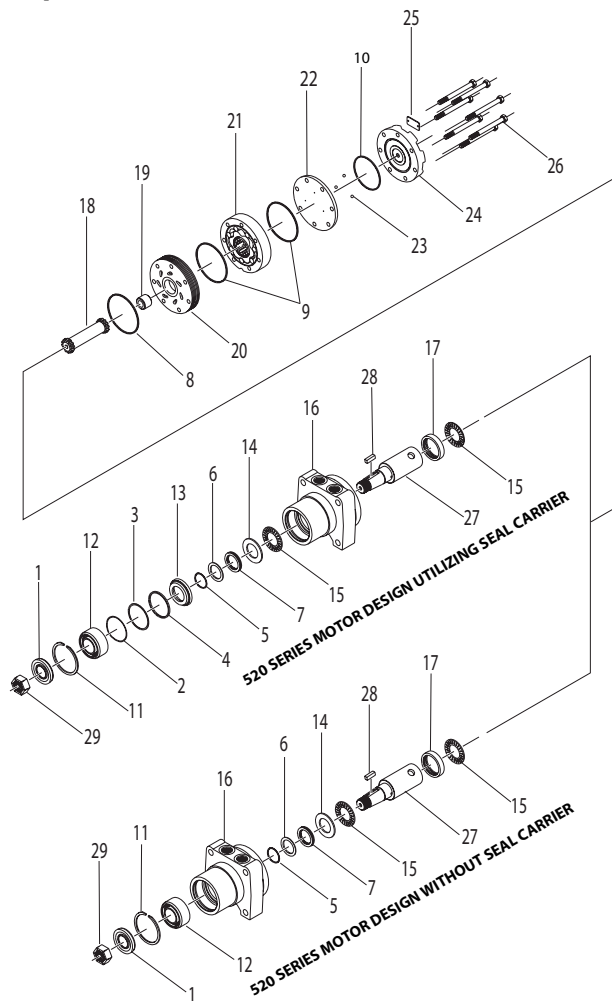

### Components List

Description	Order Number
Dust seal	1
Split wire ring	2
Metal backup shim	3
High pressure seal	4
Metal backup shim	5
Backup seal	6
Shaft seal	7
Housing seal	8
Body seal	9
Endcover seal	10

<b>Description</b>	<b>Order Number</b>
Retaining snap ring	11
72mm Bearing	12
Seal carrier	13
Thrust washer	14
Thrust bearing	15
Housing	16
Rear housing bearing	17
Drive link	18
Drive link spacer	19
Manifold	20
Rotor assembly	21
Balance plate	22
Steel ball	23
Endcover	24
ID tag assembly	25
Assembly bolt	26
Shaft	27
Shaft key	28
Shaft nut	29





---

# Chapter

# 2

---

## RE 520/521 Series Service Instructions

---

### Topics:

- *RE 520/521 Motor Section Disassembly*
- *RE 520/521 Housing/Shaft with Seal Carrier Disassembly & Assembly*
- *RE 520/521 Housing/Shaft without Seal Carrier Disassembly & Assembly*
- *RE 520/521 Motor Section Assembly*

dimensions: mm [in]

**Note:** In December 2006, the 520 Series incorporated a design change. These instructions will cover both designs. Refer to the exploded view drawing to determine which design is being repaired and follow the appropriate instructions.

All internal seals on products manufactured after July 1, 2016 are o-ring seals. Prior to this date the internal seals were square cut seals. It is recommended that if the product being serviced has square seals to replace with the square seals in this kit, likewise if the product has o-ring seals, replace with the o-ring seals in this kit.

## RE 520/521 Motor Section Dismassembly

---

### Same Instructions For Both Designs

1. Remove all shaft related components from shaft (27) (i.e. keys, wire rings, nuts).
  - a) To aid in reassembly of the motor, make a "V" shaped set of lines from the endcover (24) to the housing using either paint or a marker.
  - b) With shaft facing down, secure motor in vise by clamping on to housing (16).
2. Loosen and remove seven bolts (26) holding motor assembly together.
  - a) Remove endcover (24) and endcover seal (10).
  - b) Discard seal.
  - c) Remove balance plate (22) taking care not to drop the three steel balls (23) located in the three holes in the balance plate (22).
  - d) Remove rotor assembly (21), manifold (20), drive link spacer (19), drive link (18) and thrust bearing (15).
 

**Note:** Some motors do not use spacer.
  - e) Remove body seals (9) from rotor assembly (21) and housing seal (8) from housing (16) and discard seals.
 

**Note:** Compare old housing seal (8) to the two housing seals included in kit to determine which one to use.
  - f) Gently tap shaft (27) upward from housing (16) and remove through rear of housing and lay aside.

## RE 520/521 Housing/Shaft with Seal Carrier Dismassembly & Assembly

---

### Design That Utilizes A Seal Carrier (13)

**Note:** The motor design that utilizes a seal carrier will use the larger O.D. backup seal and shaft seal.

1. Turn housing over and remove retaining snap ring (11) from inner core of housing.
  - a) Turn housing over again.
  - b) Using a drift punch through the rear of the housing, tap against the inner race of the 72mm bearing (12) to remove the bearing through the top of the housing.
  - c) Pry dust seal (1) from bearing (12).
  - d) Then turn housing over again and push the seal carrier (13), thrust washer (14) and thrust bearing (15) down until you can get to the wire ring (2).
2. Remove wire ring (2), steel backup shim (3) and high pressure seal (4) from inner bore groove with a small screwdriver.
  - a) Lift the seal carrier (13), thrust washer (14) and thrust bearing (15) from the housing bore.
  - b) Carefully pry shaft seal (7), backup seal (6), and metal backup shim (5) from seal carrier (13) and discard.
  - c) Lay seal carrier (13), thrust washer (14) and thrust bearing (15) aside.

**Note:** If a new thrust washer (14) and seal carrier (13) is included in kit, old items may be discarded.

**Note:** At this point, all parts should be cleaned in an oil-base solvent and dried using compressed air (For safety, observe all OSHA safety guidelines). All new seals should be lightly coated in clean oil prior to installation.

3. Place shaft (27) on a clean flat surface with output end facing up.
  - a) Place thrust bearing (15) over the shaft.
 

**Note:** If thrust bearing has integral washer, make sure washer surface faces down.
  - b) Then thrust washer (14) on shaft (See Technical Bulletin PI444004 to determine correct thrust washer to use).
  - c) Lightly coat seal area of shaft with clean oil and place plastic installation sleeve with shaft seal (7) down onto shaft covering all splines, keyways and wire ring grooves.
  - d) Slide shaft seal (7) down onto shaft (27) making sure that lip on seal faces down (See *Figure 1: Figure 1* on page 11 for correct seal orientation) until it contacts thrust washer (12).

- e) Remove plastic installation sleeve.
- f) Carefully install the backup seal (6) onto the shaft (27) with the flat side up and the seal lip facing the shaft seal (7).
- g) Place the metal backup shim (5) onto the shaft and against the backup seal (6).
- h) Place the seal carrier (13) onto the shaft (large end down) and carefully press the seal carrier (13) down onto the seal assembly using an arbor press and sleeve to compress the seal into the carrier.

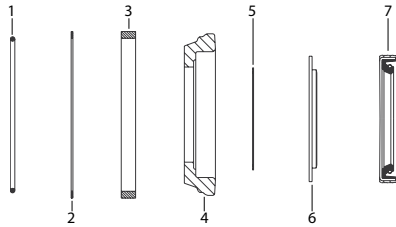

- |   |                    |
|---|--------------------|
| 1 | Wire ring          |
| 2 | Metal backup shim  |
| 3 | High pressure seal |
| 4 | Seal carrier       |
| 5 | Metal backup shim  |
| 6 | Backup seal        |
| 7 | Shaft seal         |

**Figure 1: Figure 1**

4. With pilot side facing up, place housing (16) on spacers to raise housing approximately 6.4 [.250] above work surface.

**Note:** Spacers should allow shaft to contact work surface.

- a) Place shaft/seal carrier assembly into housing (16).
- b) Install high pressure seal (4) into groove in housing.
- c) Install metal backup shim (3) against high pressure seal (4) in groove in housing bore by squeezing the shim (3) between thumb and forefinger to bow shim.
- d) While maintaining bow in shim, start the shim into the groove and use a small screwdriver to push the shim into groove.
- e) Install wire ring (2) into the groove, making sure that the ends are butted.
5. While holding shaft into housing, place housing/shaft assembly in vise with shaft end down.
  - a) Making sure that end of drive link (18) with crowned splines goes into shaft end, install drive link (18) into shaft and tap lightly to seat the seal carrier against the wire ring (2).
  - b) Place thrust bearing (15) over drive link (18).
  - c) If seal carrier (13) is properly seated against wire ring (2), thrust bearing (15) will be flush with rear surface of housing.

## RE 520/521 Housing/Shaft without Seal Carrier Disassembly & Assembly

---

### Design That Does NOT Utilizes A Seal Carrier (13)

1. Position the housing (16) in vise and use a slide and hammer type bearing puller to remove the rear housing bearing (17).
  - a) Remove the thrust washer (14) and thrust bearing (15) and set aside.

- b) Using a small screwdriver carefully pry the shaft seal (7), backup seal (6) and metal shim (5) from housing bore and discard.
2. Turn housing over and remove retaining snap ring (11) from inner core of housing.
  - a) Turn housing over again.
  - b) Using a drift punch through the rear of the housing, tap against the inner race of the 72mm bearing (12) to remove the bearing through the top of the housing.
  - c) Pry dust seal (1) from bearing (12) and discard.

**Note:** At this point, all parts should be cleaned in an oil-base solvent and dried using compressed air (For safety, observe all OSHA safety guidelines). All new seals should be lightly coated in clean oil prior to installation.

3. Place housing (16) in vice with the seven bolt assembly holes facing up.
  - a) Place metal shim (5) in the smallest diameter recess in the housing (16).
  - b) Install the backup seal (6) into the housing (16) with the flat side down and the seal lip facing up.
  - c) Insert shaft seal (7) down into housing (16) making sure that lip on seal faces up (See [Figure 2: Figure 2](#) on page 12 for correct seal orientation).
  - d) Install thrust washer (14) into housing and using an arbor press, seat the shaft seal (7) into housing (16), then place the thrust bearing (15) into housing.

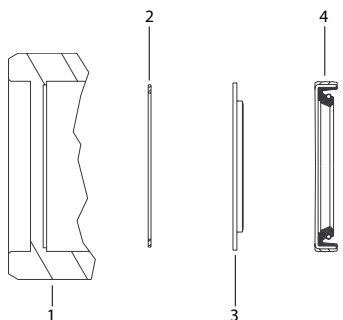

- |   |                   |
|---|-------------------|
| 1 | Housing           |
| 2 | Metal backup shim |
| 3 | Backup seal       |
| 4 | Shaft seal        |

**Figure 2: Figure 2**

4. Place the rear housing bearing (17) onto the rear housing bore and press to a depth of 3.6 [.14] from the rear surface of the housing (16) to the top of the bearing (17).
  - a) Place the shaft (27) down into housing (16) and place thrust bearing (15) on top of shaft (27).
  - b) If shaft seals are properly seated against the housing (16), thrust bearing (15) will be flush with rear surface of housing.

## RE 520/521 Motor Section Assembly

---

### Same Instructions For Both Designs

1. Install housing seal (8) into groove in housing (16).
  - a) Place manifold (20) onto housing (16) with side with only seven holes facing housing (16).
  - b) Place body seals (9) in grooves in both sides of rotor (21).
  - c) Place rotor (21) onto manifold (20) with side of rotor with chamfer in splines facing manifold (20).
2. Install balance plate (22) onto rotor (21) making sure holes for steel balls (23) faces up.
  - a) Install three steel balls (23) in holes in balance plate (22).
  - b) Install endcover seal (10) into grove in endcover (24) and place endcover onto balance plate (22).

- c) Install seven assembly bolts (26) and pre-torque to 10 ft. lbs.
- d) Using the bolt torque sequence shown in Figure 3, final torque all bolts to 67.8 Nm [50 ft. lbs.]

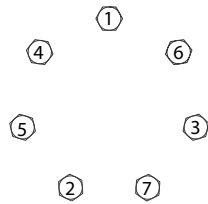

**Figure 3: Figure 3**

3. Remove motor from vise and place on work surface with shaft (27) facing up.
  - a) Place 72mm bearing (12)(Making sure that side of bearing with internal retaining ring faces down) over the shaft (27).
  - b) Using a sleeve and hammer, carefully drive bearing into housing making sure the top of the bearing falls below the groove in the housing for retaining ring installation.
    -  **Caution:** Driving the bearing down with excessive force may cause seal carrier to interfere with bearing performance. This could lead to product overheating and may shorten the life of bearing and motor. Bearing only need be tapped into place.
  - c) Install the retaining ring (11) in the groove in the housing, making sure that the ring snaps into place.
  - d) Place dust seal (1) over shaft (27) making sure side with lip faces up.
  - e) Using a sleeve and hammer, carefully drive dust seal into place.



---

# Chapter

# 3

---

## RE 520/521 Series Parts Listing

---

### Topics:

- [RE 520/521 Replacement Kits](#)

## RE 520/521 Replacement Kits

### Available Kits

Note: Refer to the [Exploded View](#) on page 6 for item numbers.

**Table 1: Seal kit**

Description	Exploded View Item Number	Qty. In Kit	Order Number
Dust seal	1	1	500444001(Includes item numbers 1-10, 13 & 14)
Split wire ring	2	1	
Metal backup shim	3	1	
High pressure seal	4	1	
Metal backup shim	5	1	
Backup seal	6	2	500444002(Includes item numbers 1-10)
Shaft seal	7	2	
Rear housing seal	8	1	
Body seal	9	2	
Endcover seal	10	1	
Seal carrier	13	1	500444003(Includes item numbers 13 & 14)
Thrust washer	14	1	

**Table 2: Miscellaneous kits**

Description	Exploded View Item Number	Order Number
Retaining snap ring	11	500018141
72mm Bearing	12	500018098
Thrust bearing	15	500018059
Rear housing bearing	17	500018002
Forward manifold	20	500015006
Reverse manifold	20	500015007
Balance plate (3 balls included)	22	500012001
Steel ball (3)	23	500018048
Endcover	24	500016001
Dust seal only	1	500018006
1000 psi relief valve	Not shown	500018228
2000 psi relief valve	Not shown	500018231
3000 psi relief valve	Not shown	500018221
1.00-20 UNEF slotted nut	29	500449304



Description	Exploded View Item Number	Order Number
1.00-20 UNEF solid nut	29	500449303
1.00-20 UNEF lock nut	29	300339303P

### Rotors, drive links and spacers, and bolts

When changing motor displacements, a matching rotor and bolt set kit ,must be ordered. A new drive link kit may be necessary. Drive link spacers are included in drive link kits, but may also be ordered separately by using the drive link spacer kit number.

Exploded View Item Number	21	21	18	19	26
Displacement	Standard Rotor Kit	Freeturn Rotor Kit	Drive Link Kit	Drive Link Spacer Kit	Bolt Set Kit
120	500087005	500087008	500014009	-	500445006
160	500137005	500137011	500014009	-	500445006
200	500167004	500167011	500014009	500018075	500445012
230	500147002	500147004	500014009	500018185	500445014
260	500227000	500227004	500014039	-	500445014
300	500247005	500247011	500014007	-	500445018
350	500207000	500207004	500014042	-	500445026
375	500307005	500307011	500014008	-	500445024
470	500357003	500357005	500014042	-	500445026
540	500407005	500407011	500014044	-	500445032
750	500607005	500607011	500014047	-	500445045

### Housing kits

Exploded view item #16

Standard housing kits include bearings (#12 & 17), dust seal (#1), and retaining snap ring (#11) installed in the housing.

Description	Order Number
#W31- wheel mount with 7/8" o-ring	500130928
#W38- wheel mount with 1/2" BSP.F	500131428
#W31- wheel mount with 7/8" o-ring with valve cavity	500133928
#W38- wheel mount with 1/2" BSP.F with valve cavity	500134428
#A51- 6-hole SAE "A" style with 7/8" o-ring ports	500135228
#A58- 6-hole SAE "A" style with 1/2" BSP.F ports	500135628
#A57- 6-hole SAE "A" style with manifold ports	500135828

Description	Order Number
#A51- 6-hole SAE "A" style with 7/8" o-ring with valve cavity	500138228

### Shafts and related components kits

Shaft kits come with related shaft components (i.e. keys, nuts, etc.). To order individual shaft components (i.e. keys, nuts, bolts, washers, or wire rings) use the kit number for each individual part.

Exploded View Item Number	27	28	29	Not Shown	Not Shown	Not Shown
Description	Shaft Kit	Key Kit	Nut Kit	Bolt Kit	Washer Kit	Wire Ring Kit
#25- 1-1/4" Tapered	500011302	500449101	See <a href="#">Table 2: Miscellaneous kits</a> on page 16	-	-	-
#07- 1-1/4" Straight	500011204	500449105		500449301	500449302	500449201
#09- 14 Tooth spline	500011107	-		-	-	500449201
#08- 32mm Straight	500011205	500449103		-	-	500449201
#03- 6B Spline	500011602	-		-	-	-
#15- 1" Straight	500011206	500449100		-	-	-