



# MOTORS

**Repair Instructions**

*RS 200/201 Series*



*together in motion*

White is a leading global provider of motor and steering solutions that power the evolution of mobile and industrial applications around the world.



## Contents

---

<b>Chapter 1 RS 200 &amp; 201 Series Diagram</b>	<b>4</b>
RS 200 & 201 Exploded View	4
<b>Chapter 2 RS 200 &amp; 201 Series Service Instructions</b>	<b>6</b>
200 & 201 Series Seal Kit Installation	6
<b>Chapter 3 RS 200 &amp; 201 Series Parts Listing</b>	<b>9</b>
RS 200 & 201 Series Replacement Kits	9

# Chapter 1

## RS 200 & 201 Series Diagram

### RS 200 & 201 Exploded View

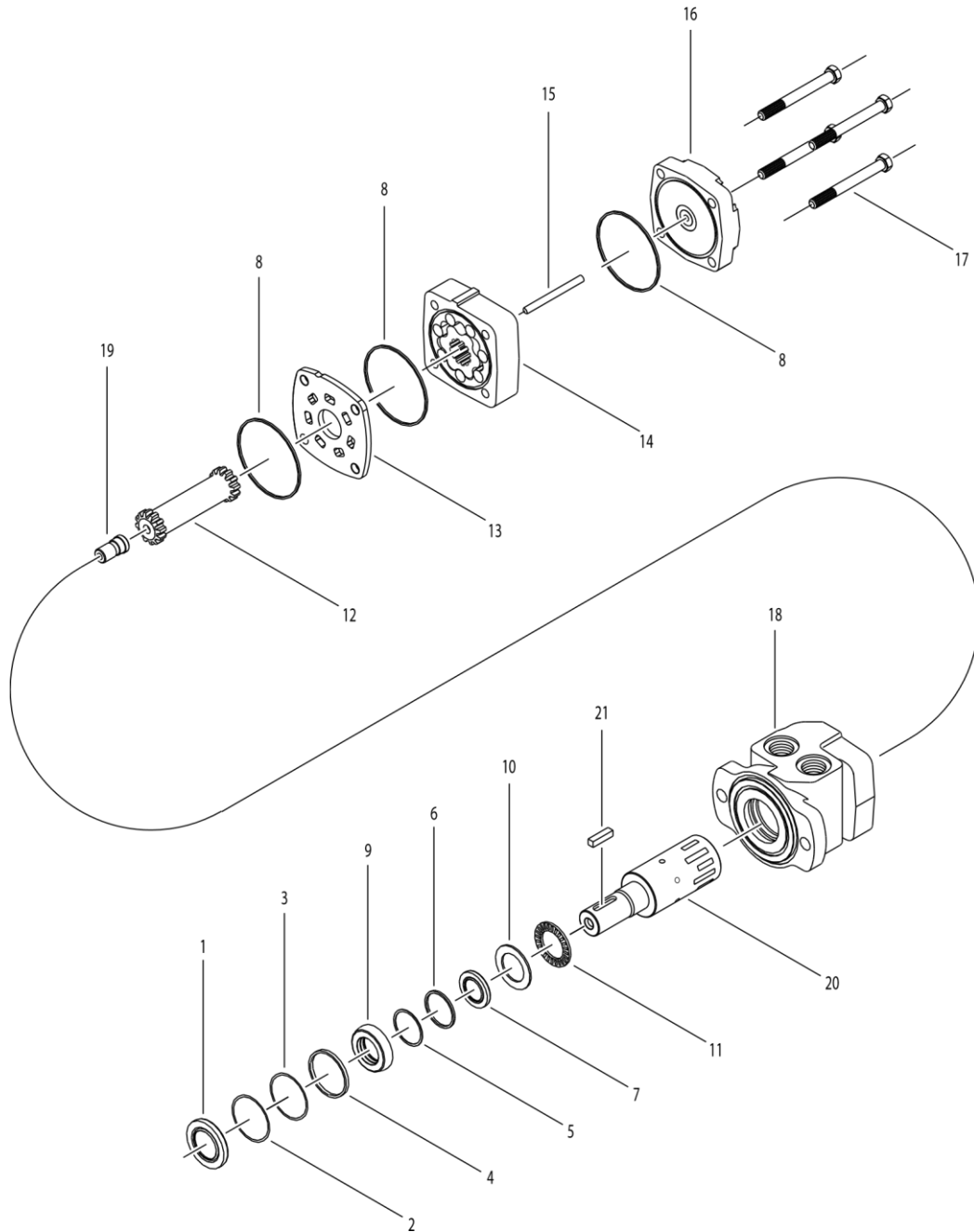

Figure 1: RS 200/201 Exploded View

Description	Item Number
Dust seal	1
Split wire ring	2
Metal backup shim	3

High pressure seal	4
Metal backup shim	5
Backup seal	6
Shaft seal	7
Body seal	8
Seal carrier	9
Thrust washer	10
Thrust bearing	11
Drive link	12
Wear plate	13
Rotor assembly	14
Drive link pin	15
Endcover	16
Assembly bolt	17
Housing	18
Cooling plug	19
Shaft	20
Shaft key	21

Table 1: Components list

# Chapter 2

## RS 200 & 201 Series Service Instructions

---

### 200 & 201 Series Seal Kit Installation

---



**Caution:** The RS 200 and 201 series motors depend on the correct orientation of parts as well as correct internal timing for proper motor operation. Before disassembling the motor, it is highly recommended that paint or a marker be used to make a “V” shaped set of lines from the endcover to the housing. This will aid in reassembling the motor components properly. It is also important that the steps involving internal parts timing be followed carefully to ensure proper motor operation.

1. Remove all shaft related components from shaft (20) (i.e. keys, wire rings, nuts). To aid in reassembly of the motor, make a “V” shaped set of lines from the endcover (16) to the housing using either paint or a marker. With shaft facing down, secure motor in vise by clamping on to housing (18).
2. Loosen and remove four bolts (17) holding motor assembly together. Remove endcover (16). Remove body seal (8) and discard seal. Remove rotor assembly (14) and wear plate (13). Remove body seals (8) from rotor assembly (14) and housing (18) and discard seals. Remove drive link pin (15) and drive link (12) from motor and lay aside.
3. Gently tap shaft (20) upward through housing (18) and remove through rear of housing. Turn shaft over and remove cooling plug (19). Remove housing (18) from vise and turn over. Pry dust seal (1) from housing. Push the seal carrier (9), thrust washer (10) and thrust bearing (11) down and remove through rear of housing. If a new seal carrier and thrust washer is included in the kit, old items may be discarded. If not, carefully pry shaft seal (7), Teflon backup seal (6) and metal backup shim (5) from seal carrier (9) and discard items 5-7. Lay seal carrier (9) aside. Remove wire ring (2), metal backup shim (3) and high pressure seal (4) from inner bore groove of housing with a small screwdriver and discard items.

**Note:** When removing items 9-11, care should be taken so that housing bore is not scratched or nicked.

**Note:** At this point, all parts should be cleaned in an oil-based solvent and dried using compressed air (For safety, observe all OSHA safety guidelines). All new seals should be lightly coated in clean oil prior to installation.

4. Place shaft (20) on a clean flat surface with output end facing up. Place thrust bearing (11) then thrust washer (10) on shaft. Install shaft seal (7) down onto shaft (21) making sure that lip on seal faces down. See below for correct seal orientation. Install the Teflon backup seal (6) onto the shaft (20) with the flat side up and the seal lip facing the shaft seal (7). Place the metal backup shim (5) onto the shaft and against the Teflon backup seal (6). Place the seal carrier (9) onto the shaft (large end down) and carefully press the seal carrier (9) down onto the seal assembly using an arbor press and sleeve to compress the seals into the carrier.

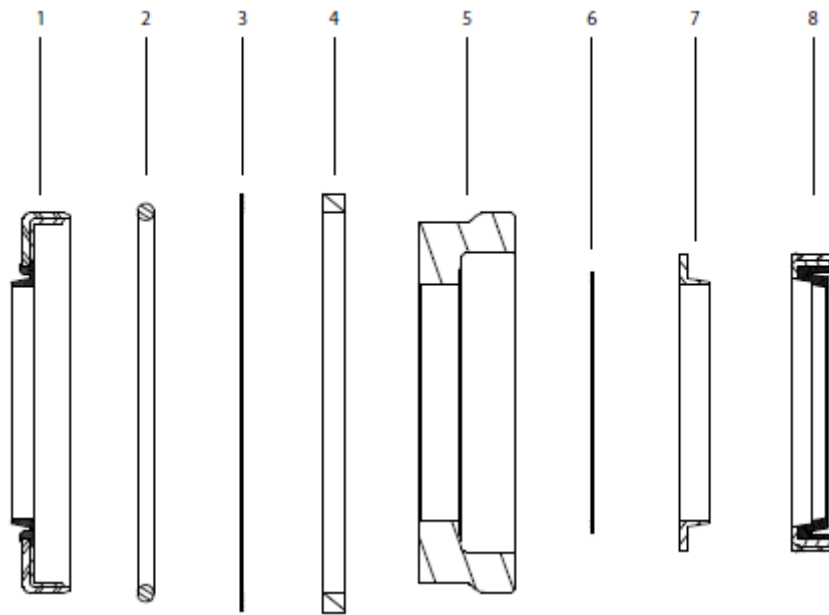

1. Dust seal
2. Split wire ring
3. Metal backup shim
4. High pressure seal
5. Seal carrier
6. Metal backup shim
7. Backup seal
8. Shaft seal

Figure 2: RS Shaft Stackup

5. Install high pressure seal (4) into groove in housing. Install metal backup shim (3) against high pressure seal (4) in groove in housing bore by squeezing the shim (3) between thumb and forefinger to bow shim (bow in the shim should be in the shape of a hill and not a valley for easier installation). While maintaining bow in shim, start the shim into the groove and use a small screwdriver to push the shim into groove. Install wire ring (2) into the groove making sure that the ends are butted.

**Note:** To return the RS Series Motors to proper operation, the rotation code of the motor must be known. The rotation code of the motor is 200 (standard) 201 (reverse timed)- the first 3 digits of the model code. If the rotational code is not known, motors that are to have the shafts turning clockwise (as viewed from the shaft end) should be timed using the “200” series and motors that are to have the shafts turning counterclockwise (as viewed from shaft end) should be timed using the “201” series.

6. Turn shaft (20) over so that output end of shaft faces down. Install cooling plug (19) down into shaft (20) making sure large O.D. end of cooling plug (17) faces up. Lower drive link (12) into shaft making sure that timing mark end of drive link faces up and that the timing mark on the end of the drive link (12) is aligned with one of the through holes in the shaft (20). When splines contact each other, slowly rotate drive link (12) counterclockwise for a “200” series, or clockwise for a “201” series motor until drive link splines engage with those on shaft (20).

7. Turn housing (18) over so that pilot of housing faces down and secure housing (18) in vise. Without disturbing seal carrier assembly (9) or drive link (12), carefully lower shaft assembly into housing. To seat seal carrier (9) against wire ring (2), gently tap drive link (12) down until end of shaft (20) is nearly flush with rear surface of housing.
8. Place a body seal (8) in the groove in the rear surface of the housing (18). Using alignment marks as a guide, place wear plate (13) on housing making sure that notch in wear plate (13) is aligned with port side of housing (18).
9. Place a body seal (8) in the groove in the face of the rotor assembly (14). Lower rotor (14) onto drive link (12) making sure that timing mark on drive link is aligned with a peak on the rotor (14) (see below).

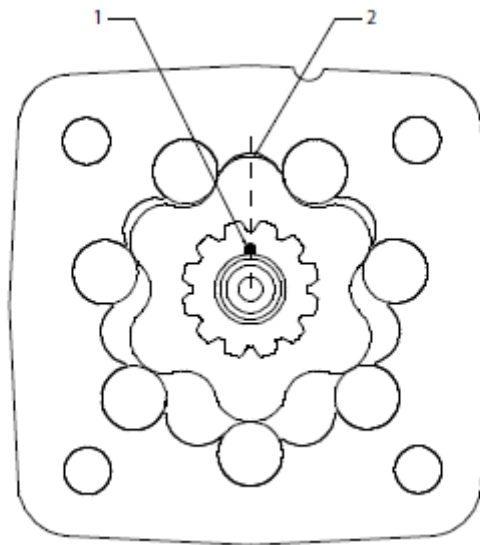

1. Timing mark on drive link
2. A peak on the rotor

Figure 3: RS drive link/rotor timing

10. Once splines are engaged, rotate rotor (14) so that notch on rotor is aligned with notch on wear plate (13) and ports on housing (18). Insert drive link pin (15) into end of drive link (12) making sure that concave end faces up.
11. Place the remaining body seal (8) in groove in endcover (16). Using alignment marks as a guide, place endcover (16) onto motor making sure that end of drive link pin (15) is in hole in center of endcover. Insert four assembly bolts (17) into bolt holes and pre-torque to 13.6 Nm [10 ft. lb.]. Using a crisscross pattern, torque bolts to 67.8 Nm [50 ft. lb.].
12. Remove motor from vise and place on work surface with shaft (20) facing up. Making sure that lip on dust seal (1) faces up, place dust seal over shaft (20). Using a sleeve and hammer, carefully drive dust seal (1) into place.



# Chapter 3

## RS 200 & 201 Series Parts Listing

### RS 200 & 201 Series Replacement Kits

#### Available Parts Kits

**Note:** Refer to the *RS 200 & 201 Exploded View* for item numbers.

Description	Exploded View Item Number	Qty. In Kit	Order Number
Dust seal	1	1	200222002 (Includes item numbers 1-8)
Split wire ring	2	1	
Metal backup shim	3	1	200222002B (Items 1-8 w/Buna shaft seal)
High pressure seal	4	1	
Metal backup shim	5	1	200222001 (includes items 1-10)
Backup seal	6	1	
Shaft seal	7	1	200222001B (items 1-10 w/Buna shaft seal)
Body seal	8	3	
Seal carrier	9	1	
Thrust washer	10	1	

Table 2: Seal kits

Description	Exploded View Item Number	Qty. In Kit	Order Number
Thrust bearing	11	1	200018011
Cooling plug	19	1	200018999
Wear plate	13	1	200012000
Mid-mount wear plate	Not shown	1	200012001
Endcover	16	1	200016003
1000 psi relief valve	Not shown	1	500018228
2000 psi relief valve	Not shown	1	500018231
¾-28 slotted nut	Not shown	1	200229300
¾-28 lock nut	Not shown	1	200018077
Manifold seal	Not shown	1	200018022

Table 3: Miscellaneous Kits

Exploded View Item Number	14	14	12	15	17
Displacement	Standard Rotorset Kit	Freeturn Rotorset Kit	Drive Link Kit	Drive Link Pin Kit	Bolt Set Kit (4)
050	200037003	200037005	200014002	200224003	200225003
080	200047004	200047005	200014002	200224008	200225004
090	200067010	200067012	200014001	200224005	200225004
100	200997001	N/A	200014001	200224008	200225010
110	200087003	200087004	200014001	200224006	200225005
125	200097003	200097004	200014001	200224008	200225010
160	200107003	200107010	200014003	200224010	200225010
200	200127009	200127011	200014003	200224012	200225012
250	200147005	200147006	200014003	200224014	200225014
300	200187009	200187011	200014003	200224018	200225018
400	200247009	200247011	200014003	200224024	200225024

Table 4: Rotorset, Drive link, Spacer and Bolt Kits

Housing Code	Order Number	Description	Order Number
F30	200013401	A62	200013606
F31	200013301	A63	200013605
A10	200013201	A19	200013105
A11	200013101	F39	200013304
F37	200013501	A68	200013607
A17	200013700	A67	200013703
A12	200013601	B18	200013612
A13	200013600	B10	200013203
A70	200013204	B11	200013106
A71	200013108	B70	200013205
A78	200013610	B71	200013109
A18	200013604	B78	200013611

Table 5: Housing Kits

**Note:** Because the housing and shaft are match ground to extremely tight tolerance, it is not recommended to replace individual housings or shafts. It is recommended that a housing/shaft kit be ordered. To order a housing/shaft kit please contact a Customer Service Representative

Exploded View Item Number	20	21
Shaft Code	Shaft Kit Order Number	Key Kit Order Number
01	200011700	N/A
02	200011600	N/A
05	200011000	N/A
10	200011100	200229100
Exploded View Item Number	20	21
Shaft Code	Shaft Kit Order Number	Key Kit Order Number
12	200011101	200229101
13	200011103	200229102
15	200011106	200229100
16	200011107	200229101

Table 6: Shaft/Key Kit(s)

**Note:** Shaft kits come with all related shaft components (shaft keys, shaft nuts, etc.).



White Drive Motors & Steering, LLC  
110 Bill Bryan Blvd, Hopkinsville, Kentucky, 42240

White Drive Motors and Steering sp. z o.o.  
ul. Logistyczna 1, Bielany Wrocławskie, 55-040 Kobierzyce

[whitedriveproducts.com](http://whitedriveproducts.com)