

# MOTORS

**Technical Information & User Manual**

*Orbital Motors with Speed Sensors*



*together in motion*

## Contents

<b>Safety precautions</b>	<b>2</b>
<b>Chapter 1 Motor with speed sensor</b>	<b>3</b>
LSHT motor with disc valve	4
Technical data for OMM EM	4
<i>Permissible shaft load</i>	4
Dimensions	5
<i>OMM EM</i>	5
<i>OMP EM</i>	6
<i>OMR EM</i>	7
<i>OMS EM</i>	8
<i>OMSW EM</i>	9
<b>Chapter 2 Installation guide</b>	<b>10</b>
Installation Guide	11
<i>Motor with speed sensor OMM EM, OMP EM, OMR EM, OMS EM, OMSW EM</i>	11
<i>Connection</i>	11
<i>Speed signal</i>	12
<i>Connection diagram</i>	12
<i>Connection diagram</i>	12
Testing	13
<i>Measuring - duty cycles</i>	13
<i>Measuring - revolutions per minute</i>	13

# Safety precautions

---

Always consider safety precautions before beginning a service procedure. Protect yourself and others from injury. Take the following general precautions whenever servicing a hydraulic system.

## Unintended machine movement



**Warning:**

*Unintended movement of the machine or mechanism may cause injury to the technician or bystanders. To prevent unintended movement, secure the machine or disable / disconnect the mechanism while servicing.*

## Flammable cleaning solvents



**Warning:**

*Some cleaning solvents are flammable. To eliminate the risk of fire, do not use cleaning solvents in an area where a source of ignition may be present.*

## Fluid under pressure



**Warning:**

*Escaping hydraulic fluid under pressure can have sufficient force to penetrate your skin causing serious injury and/or infection. This fluid may also be hot enough to cause burns. Use caution when dealing with hydraulic fluid under pressure. Relieve pressure in the system before removing hoses, fittings, gauges or components. Never use your hand or any other body part to check for leaks in a pressurized line. Seek medical attention immediately if you are cut by hydraulic fluid.*

## Personal safety



**Warning:**

*Protect yourself from injury. Use proper safety equipment, including safety glasses, at all times.*

# Chapter 1

## Motor with speed sensor

---

### Topics:

- *LSHT motor with disc valve*
- *Technical data for OMM EM*
- *Dimensions*

## LSHT motor with disc valve

---

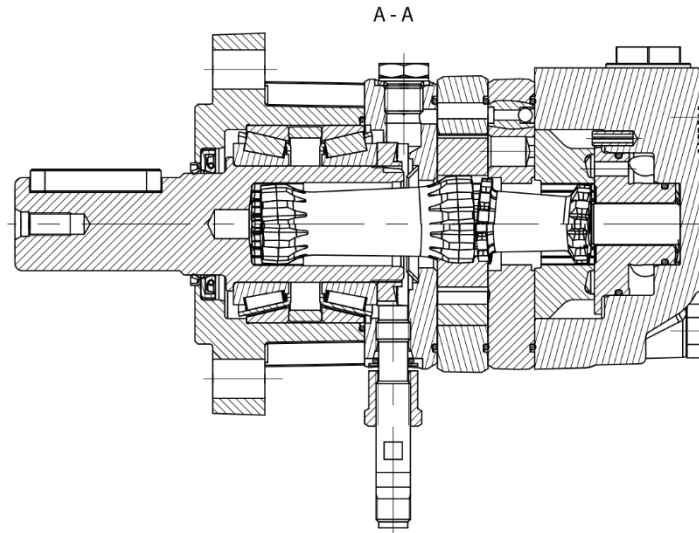

Figure 1 LSHT motor with disc valve

## Technical data for OMM EM

---

### Permissible shaft load

*Permissible radial shaft load must be reduced by 30% compared to motors without speed sensor.*

## Dimensions

### OMM EM

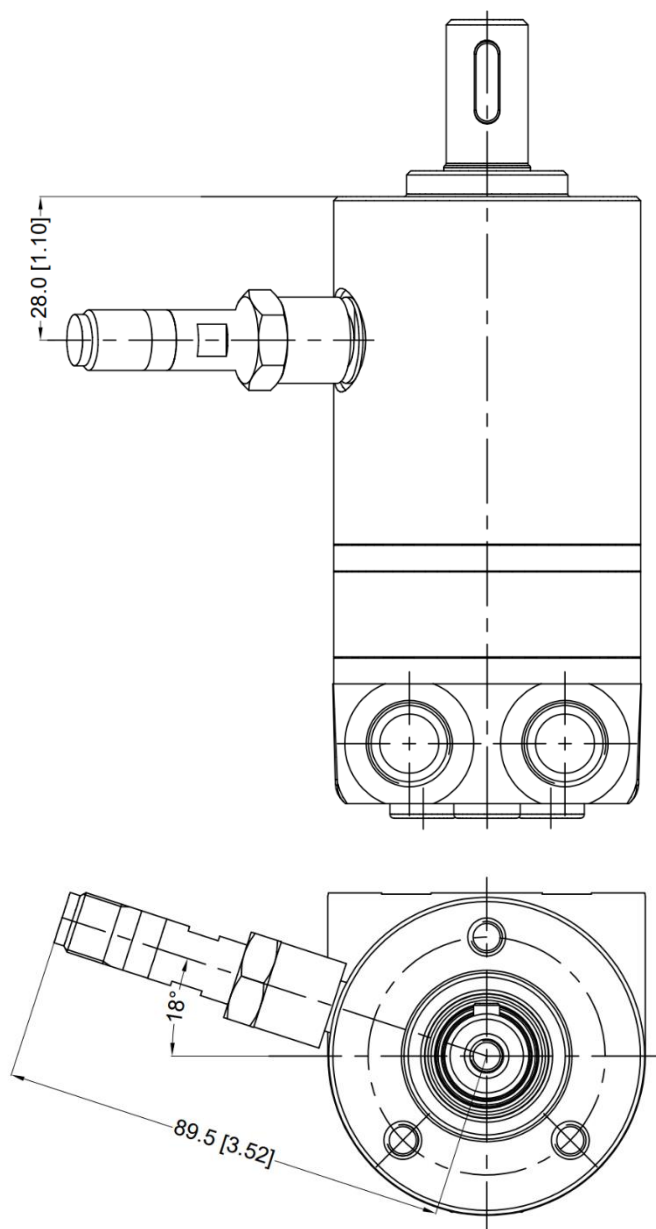

Figure 2 OMM EM

**OMP EM**

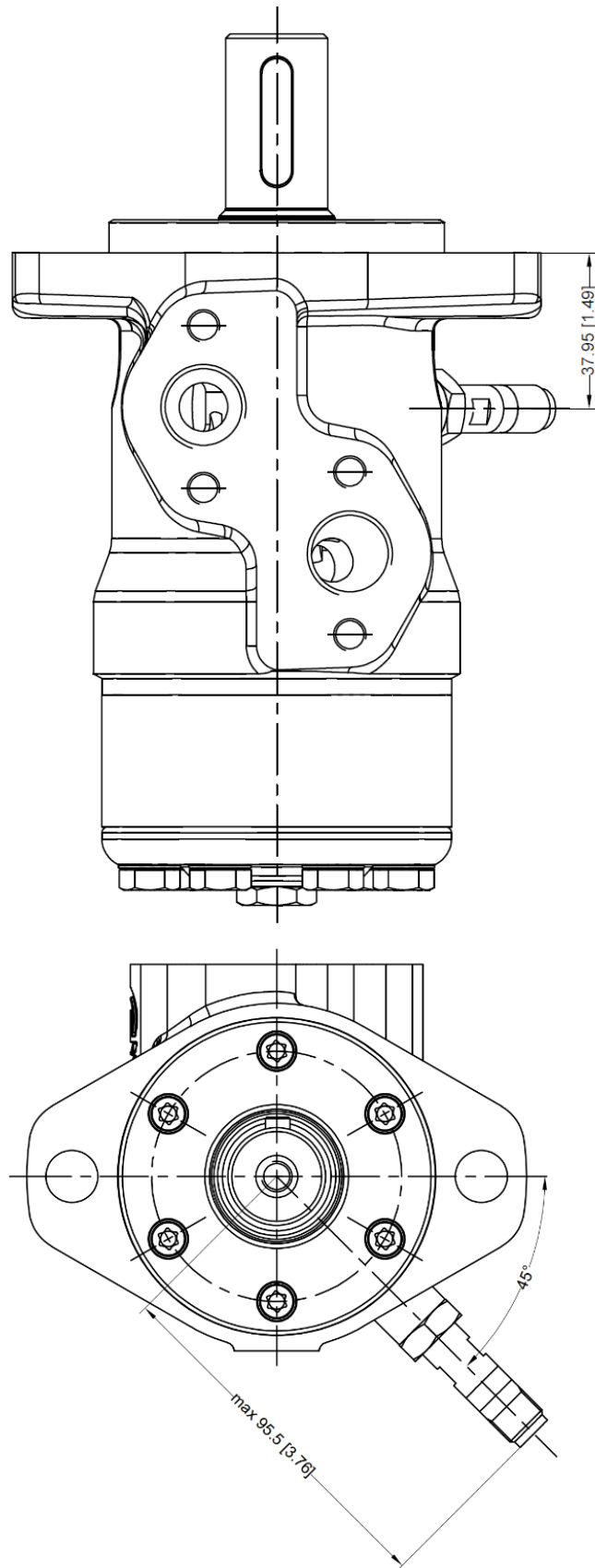

Figure 3 OMP EM

**OMR EM**

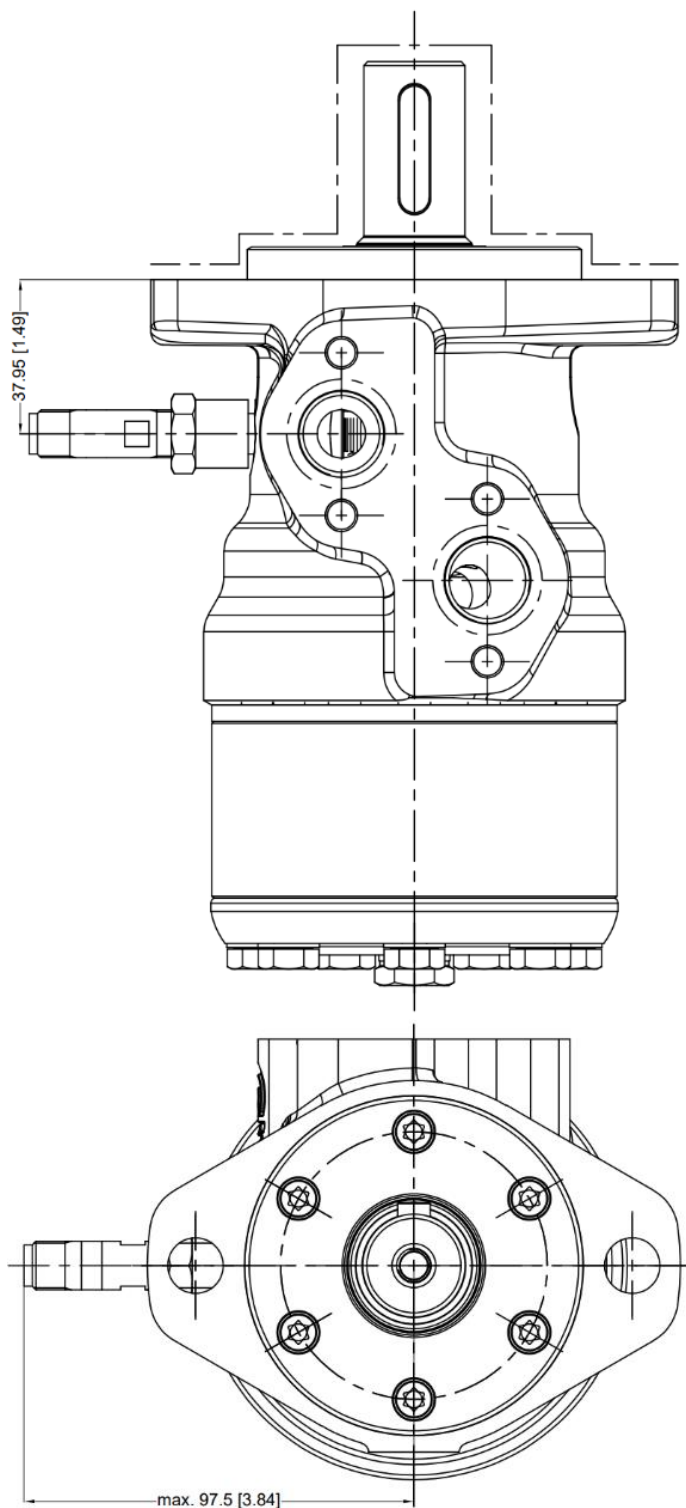

Figure 4 OMR EM



**OMS EM**

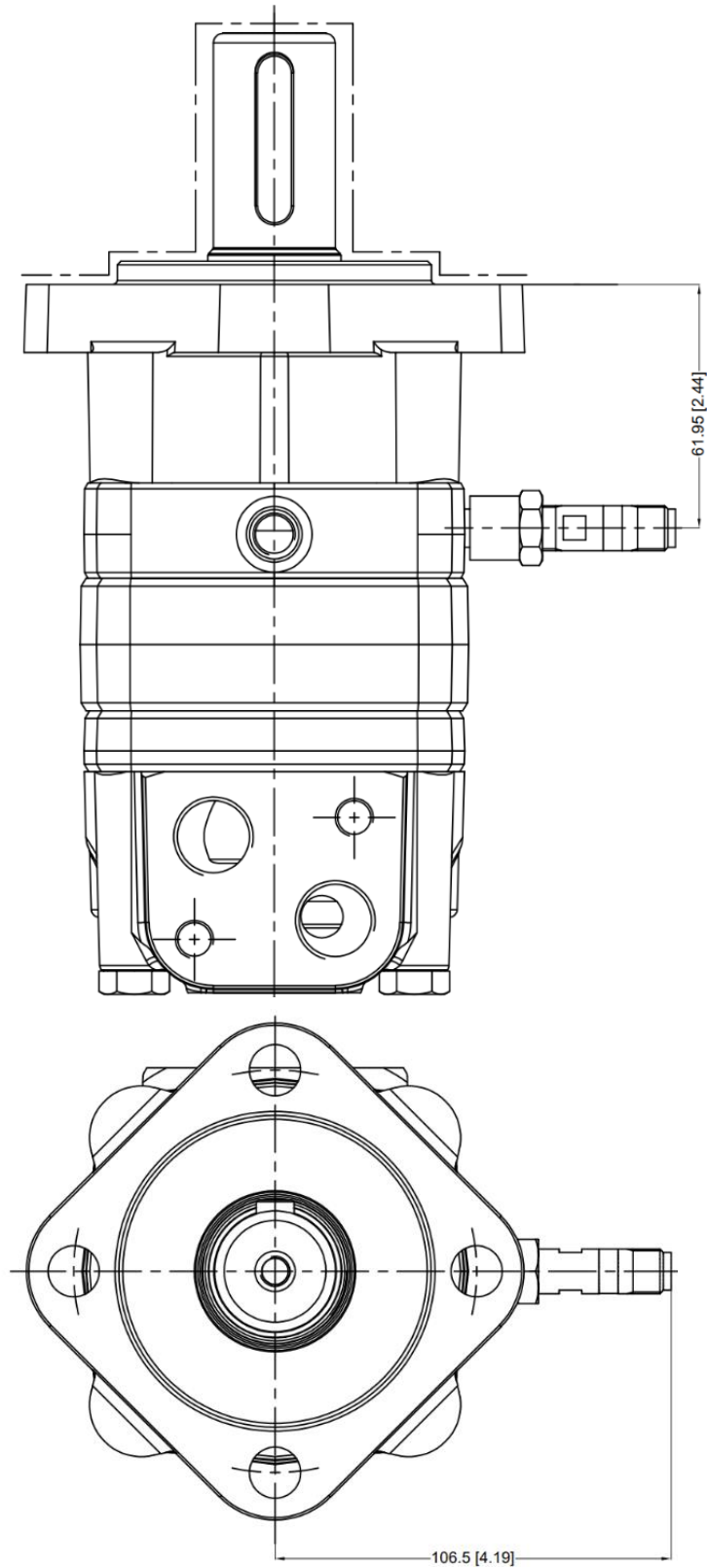

Figure 5 OMS EM

**OMSW EM**

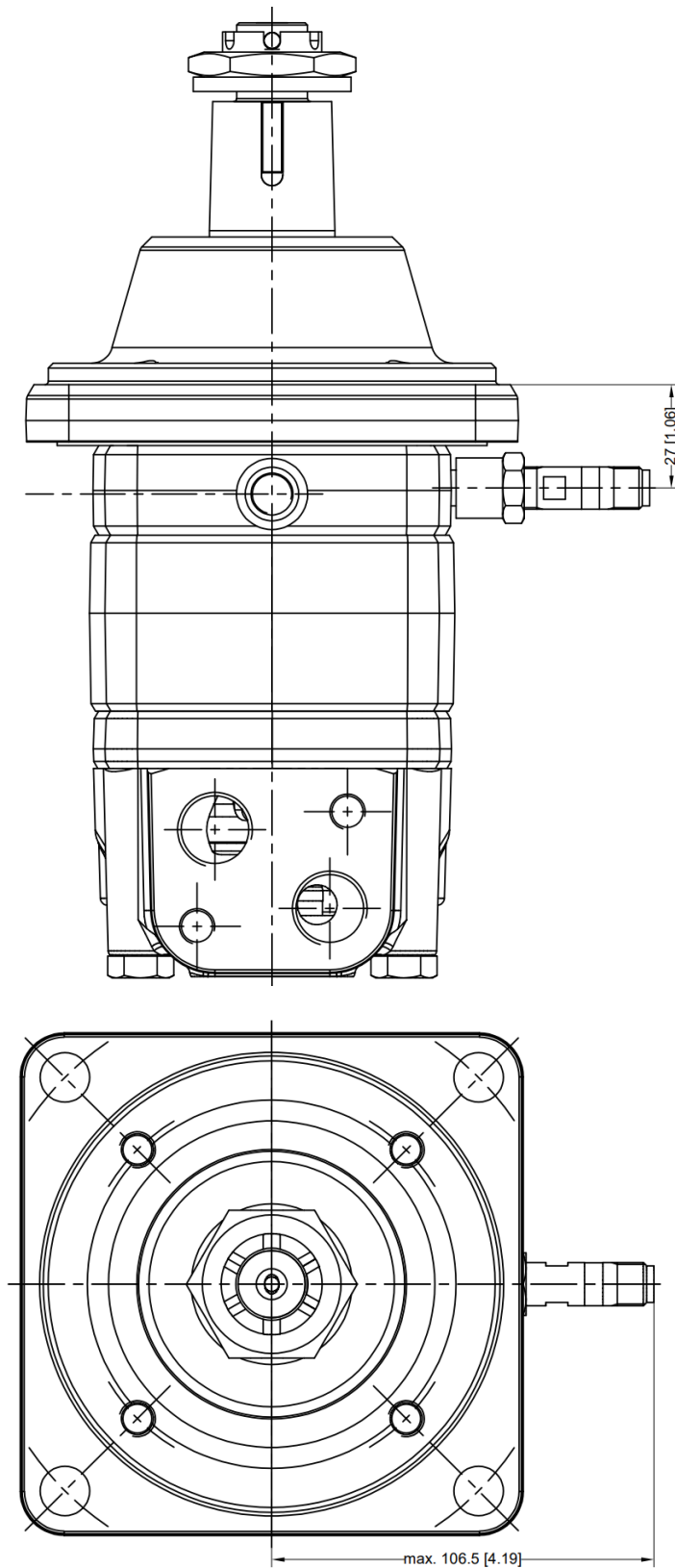

Figure 6 OMSW EM

## Chapter 2

# Installation guide

---

### Topics:

- [Installation Guide](#)
- [Testing](#)

## Installation Guide

### Motor with speed sensor OMM EM, OMP EM, OMR EM, OMS EM, OMSW EM

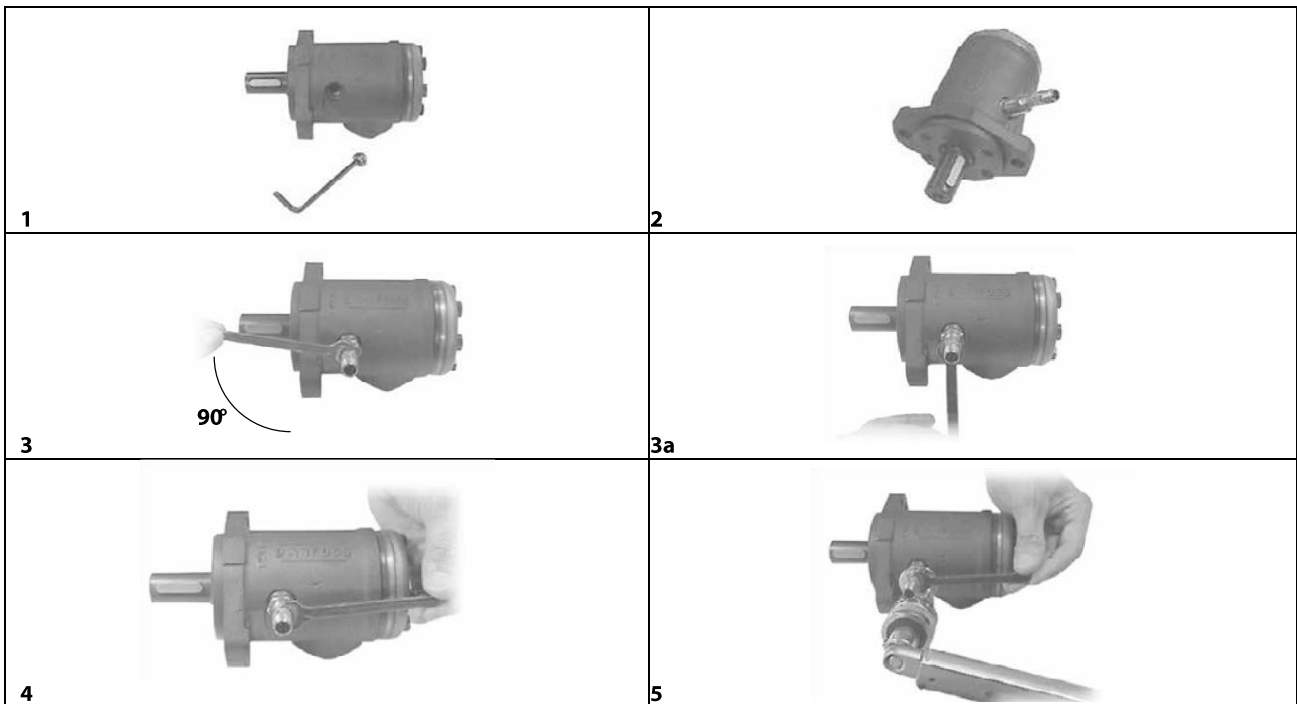

1. Remove the plug and washer from the motor (6 mm Allen key).
2. Without tools screw in the sensor till it makes contact with the shaft/nut of the motor.
3. Turn 1/4 revolution back again (90°) as shown on *photo 3a*.
4. Turn back further until the 10 mm flats of the sensor are aligned with the longitudinal axis of the motor. Tolerance  $\pm 5^\circ$ .
5. Keep the sensor in this position while tightening the compression nut to the prescribed torque of 15-20 Nm.

To make the sensor work, be sure to carry out the steps 2 – 5 correctly and in the right order of succession.

### Connection

**Attention: Don't turn the socket**

Connection: Binder series 713

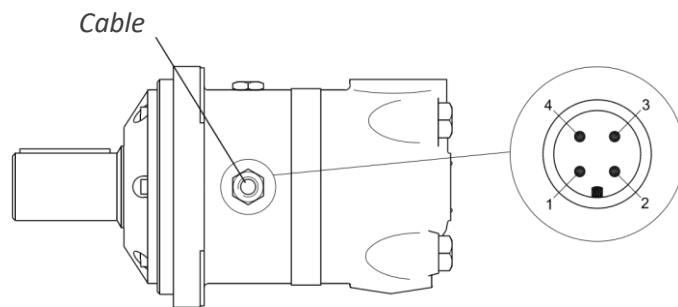

Pin	Conductor	Designation	Specification
1	Brown	Supply	11 - 30 V <sub>===</sub>
2	White	Not connected	
3	Blue	Supply	0V <sub>===</sub>
4	Black	Signal	See below

## Speed signal

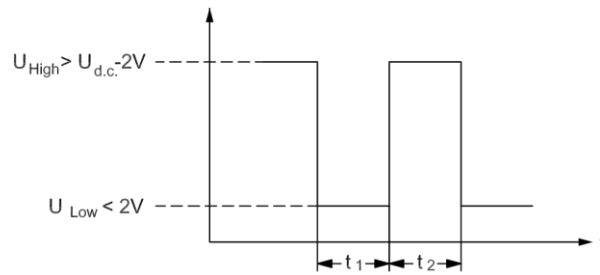

$$t_1 = t_2 \pm 10\%$$

Motor type	OMM EM	OMP EM	OMR EM	OMS EM	OMSW EM
Pulses per rev.	22	35	35	55	55
Load	$I_{\max} = 50 \text{ mA}$				

## Connection diagram

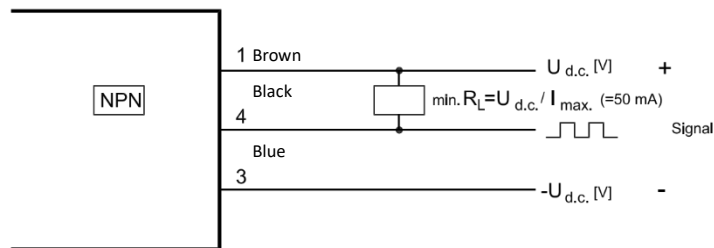

## Connection diagram

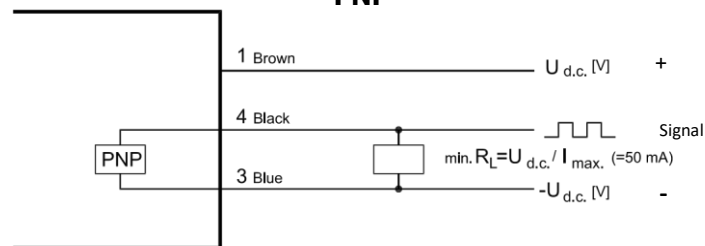

# Testing

## Measuring - duty cycles

1. Mount the sensor in motor in accordance with **DOC00031192 (NPN)** or **DOC00031191 (PNP)** and place the motor in the test panel.
2. Connect power supply and multimeter (with Hz measuring option) as described in the diagram.
3. Set rotary switch of multimeter on V and activate Hz pushbutton twice (for % measuring).
4. With an oil flow to the motor sufficient to ensure even revolution with a warm motor.

Measure the following duty cycles:

Motor type	Duty cycle (%)
OMM EM	50 +/- 10
OMP EM	55 +/- 5
OMR EM	55 +/- 5
OMS/OMSW EM	55 +/- 5

## Measuring - revolutions per minute

Measure also the frequency ( $F_r$ ) with the multimeter and calculate the revolutions per minute and compare it with RPM-counter on the test panel.

$$RPM = \frac{F_r * 60}{PPR}$$

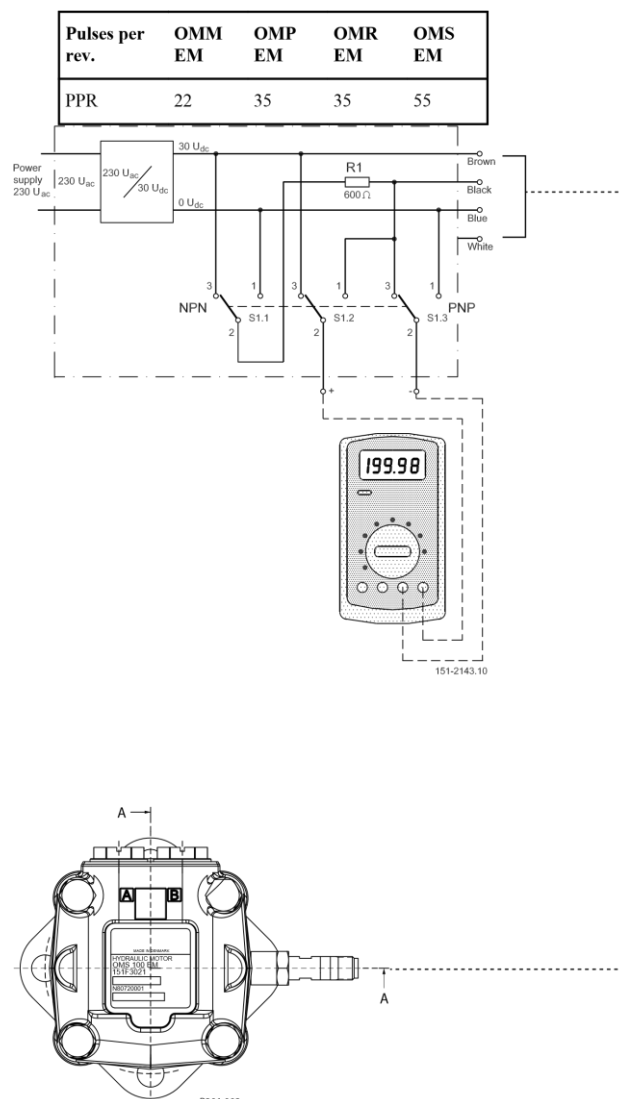

Figure 7 Resolution



White Drive Motors & Steering, LLC  
110 Bill Bryan Blvd, Hopkinsville, Kentucky, 42240

White Drive Motors and Steering sp. z o.o.  
ul. Logistyczna 1, Bielany Wrocławskie, 55-040 Kobierzyce

[whitedriveproducts.com](http://whitedriveproducts.com)